



MOTEX ENGINEERS

AN ISO CERTIFIED COMPANY



MOTEX ELEVATOR Change Your Experience

ABOUT OUR COMPANY

We are one of the well-known & reputed Supplier to offer the Lift (Passenger Lifts, Goods Lift ,Goods Cum Passenger Lifts) and Fire Fighting System.

Customer satisfaction is our main focus, we understand our client's requirements and their expectations. We strive in continuous improvement and believe in operational excellence to meet customer's expectations

VISION

Motex Engineers Provide Outstanding Products and Unsurpassed Service that ,Together deliver Premium value to Our Customers.

We works together across boundaries, to meet the needs of our customers and to help the company win.

We shall exceed customer expectation through dedicated efforts, quality work, and commitment, transparent and fair operations.”



Our experts are always available for the service or installation supports or queries, either telephonic or visiting the site. We don't pull off our support at any point in time, its on-site and on-time.



Motex Engineers provide most helpful service experts which are always on hand to keep your portfolio of equipment moving. our young and dynamic service technicians are in tune with the new technologies and are aware of the latest trends in the elevators technology.

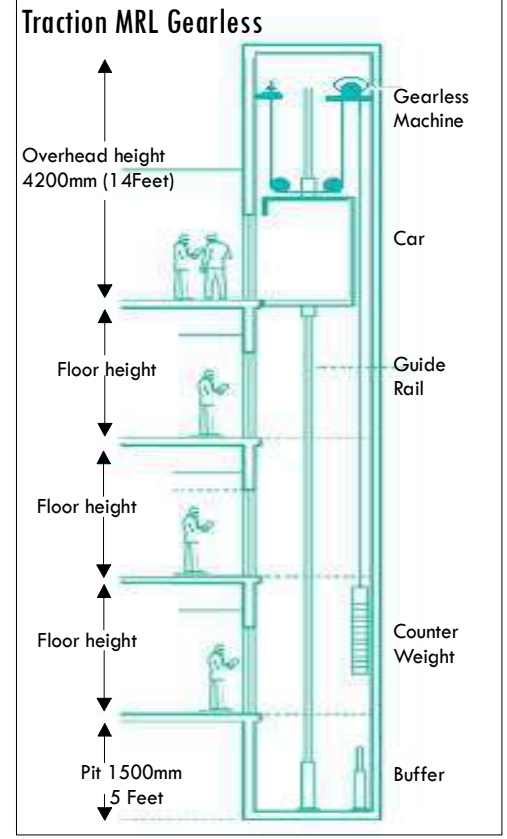
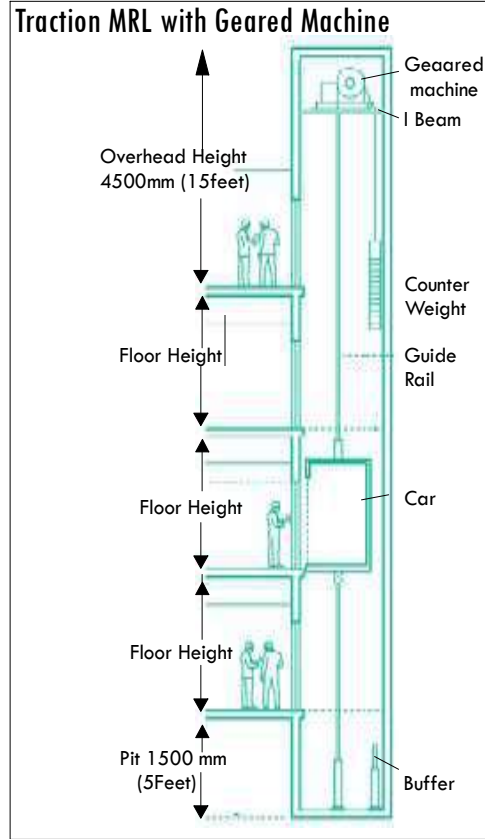
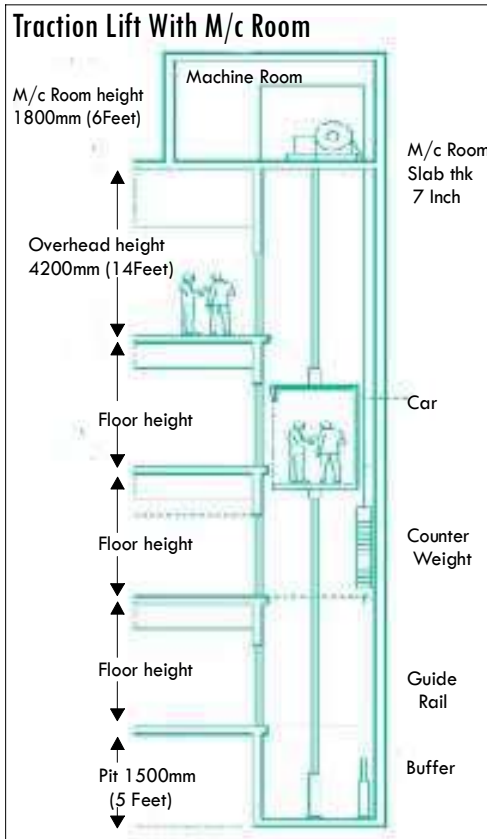

Recommended dimensions of passenger lifts

Load	Persons	Kg	Lift Well		Car Inside		Entrance
			Width	Depth	Width	Depth	
4	4	272	1900	1300	1100	700	700 (min)
6	6	408	1900	1700	1100	1000	700 (min)
8	8	544	1900	1900	1300	1100	800
10	10	680	1900	2100	1300	1350	800
13	13	884	2500	1900	2000	1100	900
16	16	1088	2500	2100	2000	1300	1000
20	20	1360	2500	2400	2000	1500	1000

Recommended dimensions of goods lifts

Load	Kg	Lift Well		Car Inside		Entrance
		Width	Depth	Width	Depth	
500	500	1900	1500	1100	1200	1100
1000	1000	2300	2100	1400	1800	1400
1500	1500	2600	2300	1700	2000	1700
2000	2000	2600	2800	1700	2500	1700
2500	2500	2900	2800	2000	2500	2000
3000	3000	2900	3300	2000	3000	2000
4000	4000	3400	3300	2500	3000	2500
5000	5000	3400	3900	2500	3600	2500

Recommended dimensions of hospital lifts

Load	Persons	Kg	Lift Well		Car Inside		Entrance
			Width	Depth	Width	Depth	
15	15	1020	1800	3000	1000	2400	800
20	20	1360	2200	3000	1300	2400	1200
26	26	1768	2400	3000	1600	2400	1200

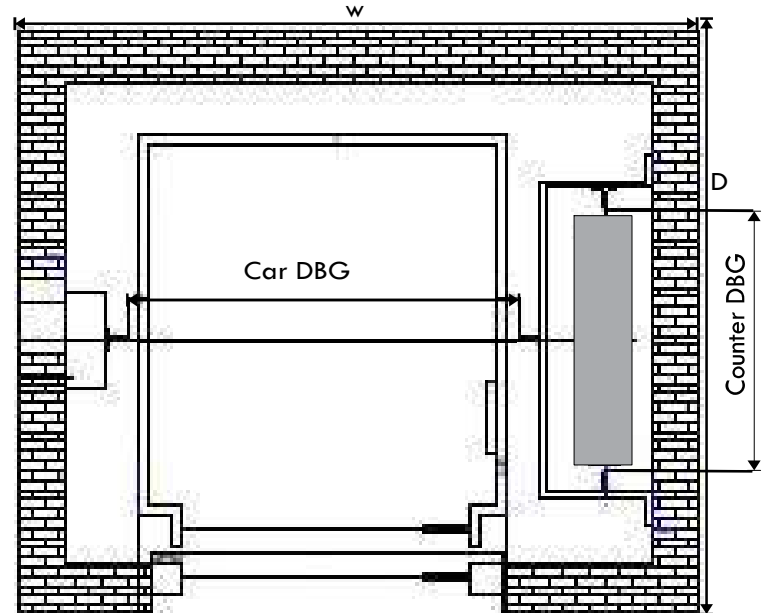

All Dimensions are in mm.
 Pit Depth size 1500 mm.
 Lift Room Slab thickness 7 inch.
 Over Head height 4200 mm in MR Lift.
 Overhead height 4200 mm in MRL Lift.

Dimensions of pit depth and overhead may differ in practice as per individual manufacturer's design depending upon load, speed and drive.

All dimensions given above are recommended dimensions primarily for architects and building planner. Any variations mutually agreed between manufacturer's and purchaser are permitted.

Traction Gear Machine with Machine Room

Traction Elevators lifted by rope, which pass over the wheel attached to an electric motor above the elevator shaft. They are used for mid and high-rise applications and have much higher travel speeds than hydraulic elevators.

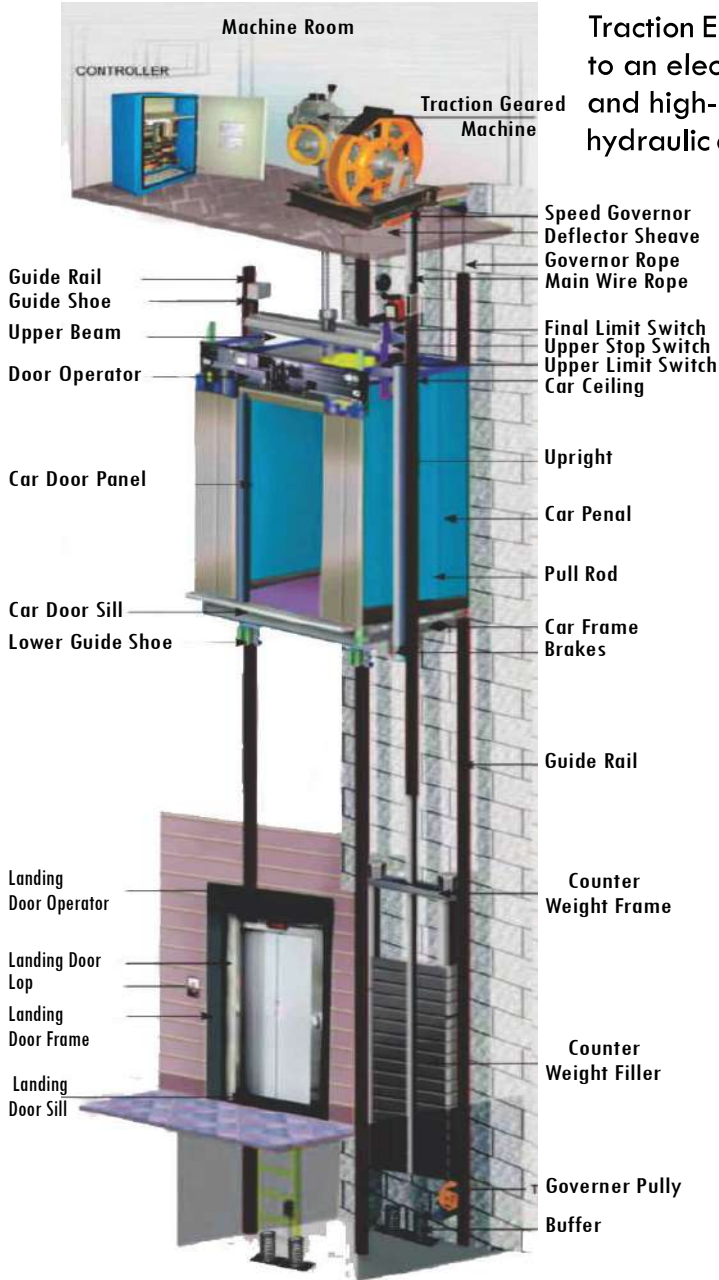

Geared Traction Elevators have a gearbox that attached to the motor, which drives the wheel that moves the ropes. Geared traction elevator are capable of travel speeds up to 500 feet per min. The maximum travel distance for a geared traction elevator is around 250 feet.



Manual Door Lift

Manual Door Elevators for economically suited all type of residential & commercial buildings upon the shaft size with speed/ amenities up to owner choice.



Manual Door Designs



M.S. Swing Door



Wooden Swing Door



M.S. Telescopic Door



Collapsible Door

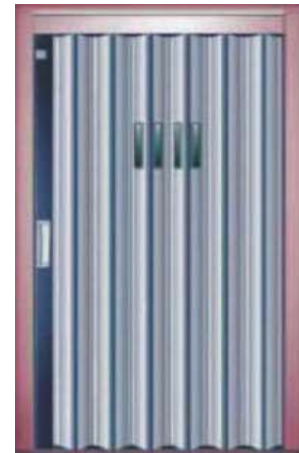

Imperforate Door

Automatic Door Lift

Auto Door Elevators for residential, commercial buildings, Hotels, Malls, Clubs & Bungalows depending upon the shaft size with speed/amenities up to owner choice.

AUTO DOOR DESIGNS



MULTI-BEAM DOOR SENSOR

Multiple infrared-light beams cover a door height of approximately 1800 mm to detect passengers or objects as the doors closer

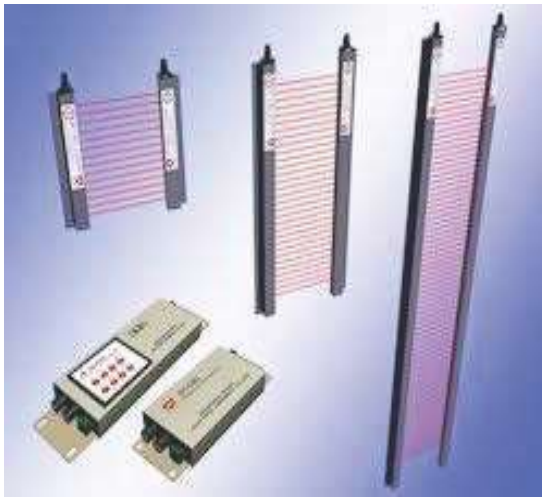

Center Opening
S. S. Auto Door



Center Opening
Small Vision Door



S. S. Telescopic
Auto Door



Full Vision S. S.
Glass Door



Gold Finish Big
Vision Glass Door



Big Vision S. S.
Glass Door

Door Operating System



Half Vision S. S.
Glass Door



Center Opening
M. S. Auto Door



M. S. Telescopic
Auto Door

Door Opening 600, 650, 700, 800, 900, 1000 & 1200 MM

Traction Gearless Machine without Machine Room (MRL)



Gear-less Traction Elevators have the wheel attached directly to the motor is this design. In fact, gear-less traction elevators are able to travel at speeds of up to 2000 feet per minute which makes them perfect choice for building. Gearless machine for elevators powered by a permanent magnet synchronous motor. compact modular design, light weight and low operating noise levels make it especially suitable for machine room-less applications. It has outstanding torque and cogging characteristics and no oil spillage problems. Real saving in energy consumption, space and routine maintenance, contribute to significant reduction in cost of ownership.



ADVANTAGE

- ◆ Latest Technology
- ◆ Smoothest Travel
- ◆ Absolute Freedom in Building Design
- ◆ Save Construction Cost
- ◆ Compact Design of Machine
- ◆ Low maintenance cost
- ◆ No machine room required
- ◆ More safe
- ◆ Space Saving
- ◆ Less Noise

CAR Design



ME-SS.GF-039



ME-SS.GF-041



ME-SS.GF-042



ME-SS-019



ME-SS-021



ME-SS.GF-021



ME-SS-027



ME-SS-026



ME-SS.GF-043



ME-MS-009



ME-SS-023



ME-SS-022

COP & LOP

Wall Mounted Button COP - LOP



HANDRAIL DESIGN

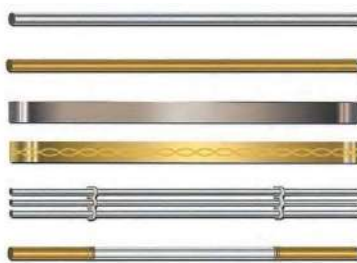

FLOOR Design



Automobile Elevators

In Motex Car elevators are immaculately designed to carry the load and spaciousness to accommodate the various size of cars available in the market. precision in design and safety are the paramount and prerequisite while designing car elevators.

Motex car elevators come with both, single side and two side opening option.



Scissor Lift

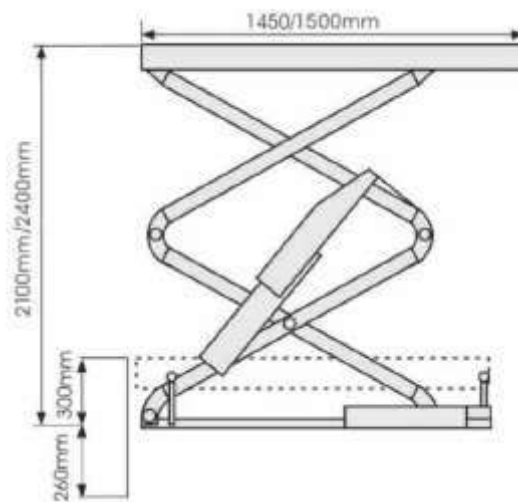

Scissor lift is design for multiple usages in the workshop on the checking and service of vehicle service, auto body beauty and other repairing jobs on the vehicle. Safety locking device is being integrated to stop the lift from lowering when there is a sudden interruption on the electrical power supply.

Hvdraulic Car Elevators



Car Stacker Parking



Hydraulic

Hydraulic Passenger Lifts offered by us are designed specially to meet the varied customer's requirements in best possible manner. These lifts are installed in commercial buildings, offices and other places in order to make the movement easy. Made using advanced technology, our range is best in terms of performance and quality.

Advantages

- Eco Friendly product
- Anti-resistant
- Flexible setting of the machine room positions
- Wide Loading range , strong adaptability
- High performance
- Durable



Motex Engineers Elevators Gives You

- Safe, secure and powerfull Transpotation
- A longer operating lifeline.
- Comfort and low noise.
- Simple and fast Installation.
- Down time power free.
- ARD (Auto rescue device)



Piston



Car Frame



Power Pack



Pump Valves



Oil Seal



Component



Switch Button

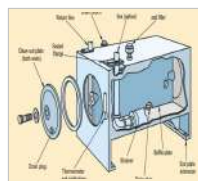

Reservoirs



Manual Hand Pump



Oil Tank



EV-100



ME-GR-03



ME-GR-06



ME-GL-07



ME-GL-09



ME-GL-05



CONTROLLER FOR MANUAL DOOR LIFT



CONTROLLER FOR AUTO DOOR LIFT



INTEGRATED CONTROLLER FOR GEARLESS MACHINE



DRIVE



MONOSTABLE SWITCH

LIMIT SWITCH



GUIDE RAIL



ELEVATOR ROPE



ARD



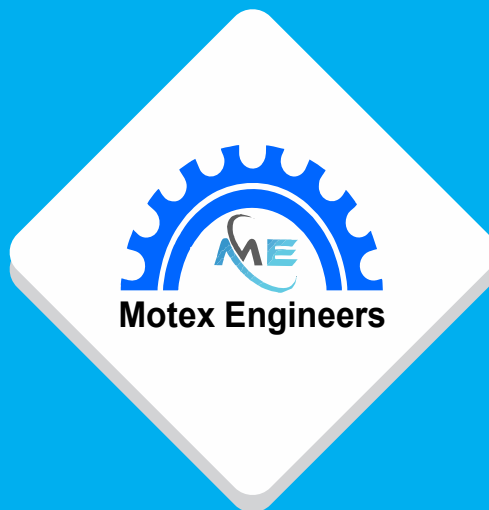

MOTEX ENGINEERS

Head Office : Plot No. 752 Sharda Vihar, Bithoor Road, Near Blue world Kanpur, U.P. - 209217
Service Office : 1- House No. 119/517 Kalpi Road Darshan Purwa Fazalganj Kanpur
: 2- Plot No-166 Gopal Nagar, Kanpur-208011
Website : www.motexengineers.com **Email** : info@motexengineers.com
Contact No. : 7048955303, 8770804926, 7011590857, 9450904634